



Instructions

for Product
Handling and
Movement

Big Bag

Instructions for handling and movement



1. Big Bag composition



BIG BAG 1.250 kg:

- Cylindrical/sealed Big Bag made in raffia/vinyl, with capacity for up to 1,250 kg.
- It has four handles and may contain a 1.10 m x 1.10 m pallet at the base.
- It has identification items: seal and label with batch and product description.

For another Big Bag and information on sizes, please contact the customer service area of Braskem.

2. Receipt of products in Big Bag packaging

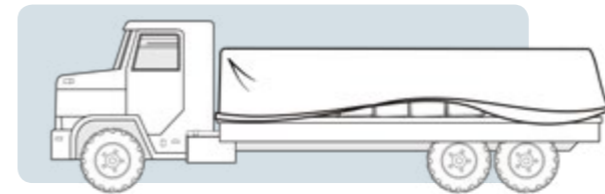

- When unloading cargo in tarps, be careful regarding the accumulation of water on top of the tarp. It should be removed by rolling it from the front to the rear of the vehicle, and never from the side, thus preventing any water that may be on the tarp from wetting the product when pulling it.
- Check the load at the time of receipt. Fill in and sign the RID (Unloading Inspection Report), which is included in the invoice. Properly filling in the RID is essential to ensure that any non-conformities are addressed. This document should be filed in, signed, stamped and delivered to the driver, along with the invoice slip.

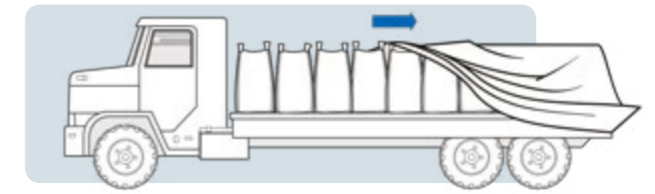

- Packaging problems during unloading, whenever possible, should be photographed at the time of detection, while still on the vehicle. Send us the file or files of any damaged packages, plus seals, labels and Big Bag numbers so we can take the necessary steps to replace the material, as well as any corrective actions, as soon as possible. Separating the damaged packaging may be useful for future inspection.
- If you have any questions on unloading, please contact the customer service area of Braskem.

* Images for illustration purposes only.

3. Handling of products in Big Bag packaging

Forklift handling of Big Bags should be carried out according to the instructions below:

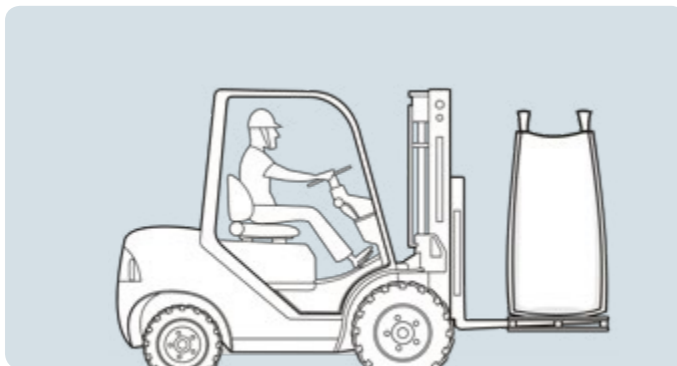
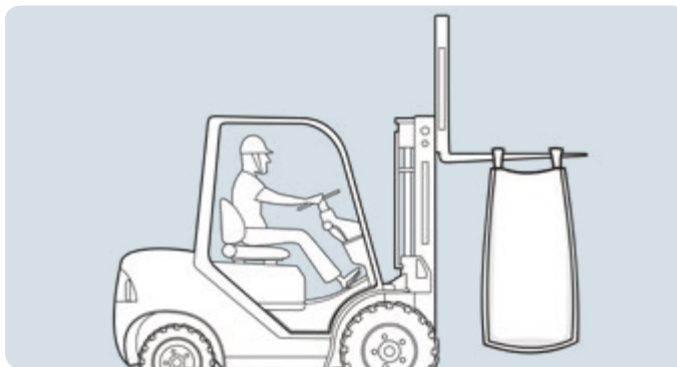
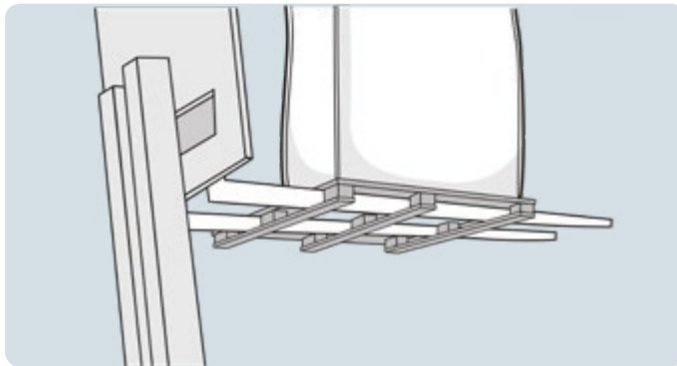
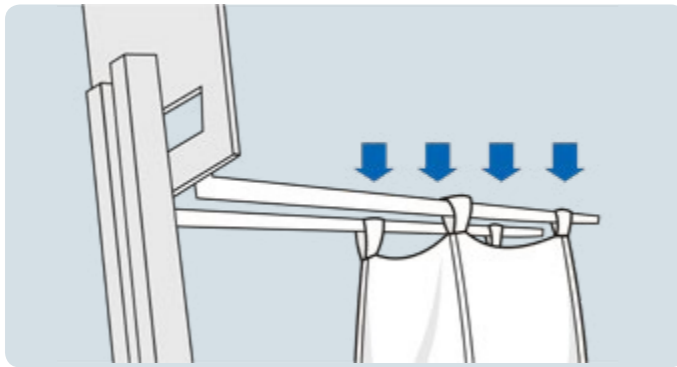

- The unloading can be performed by lifting the Big Bag, as well as by moving the wood pallet, if any.
- When using the handles to move the Big Bag, it is essential that all four handles be lifted at the same time.
- When lifting the Big Bag, pay attention to the condition of the forklift forks, which should not have sharp edges.
- The forklift operator should carry one Big Bag at a time to their place of storage. Handling more than one Big Bag at a time is not recommended.

4. Storage of products in Big Bag packaging

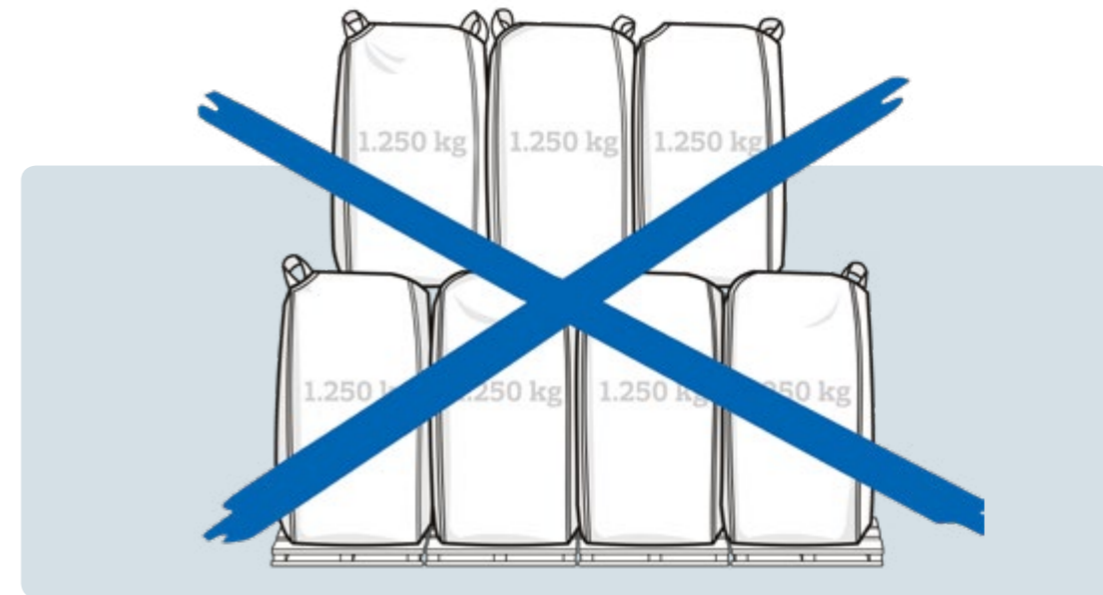

Storage of Big Bags packaging should follow the following rules:

- Stacking is not recommended as it may cause fall of the material and pallets breaks. For EVA resins, the stacking also generates risk of resin agglomeration.
- Wood pallets included in the packaging should not be used in drive-type vertical structures.
- Big Bags made in raffia and vinyl should be stored in clean and dry places, avoiding direct contact with soil.
- Big Bags made in vinyl can be stored outdoors. Keep in mind that they should never be kept in places where there is standing water.
- It is important to keep the seals during the period of use of the material. In the event of any abnormality, please contact the customer service area of Braskem and provide the number.
- Please refer to the MSDS for information on handling and storage.

We recommend that all procedures comply with the regulations on use of the necessary PPE and CPE, as well as the applicable rules and procedures.

*Images for illustration purposes only.

Palletized Sacking

Instructions for handling and movement



1. Palletized sacking composition

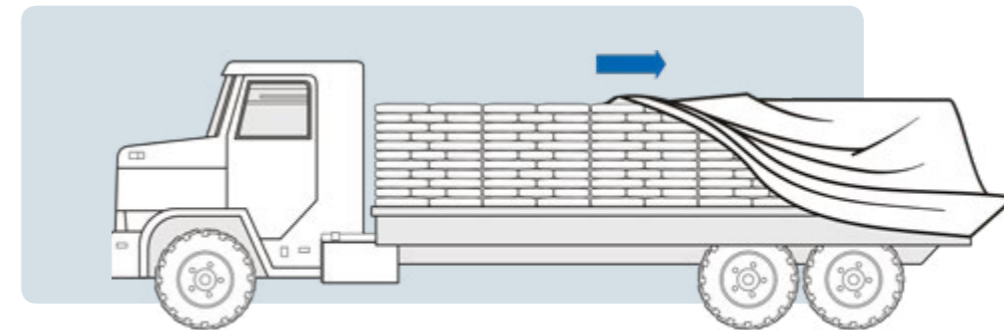
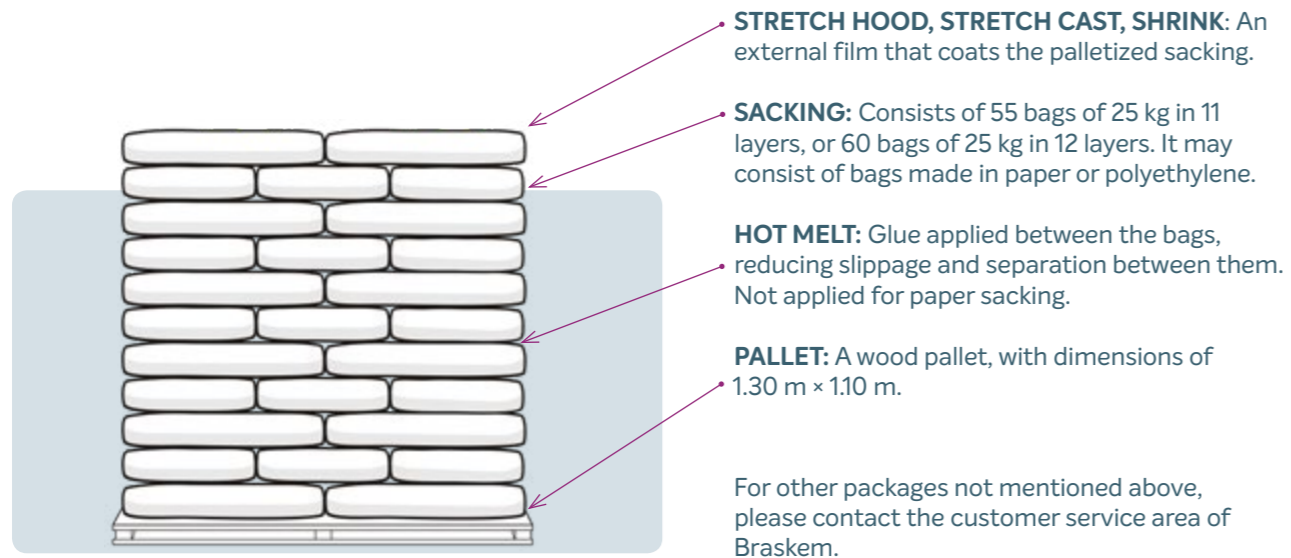

2. Receipt of palletized sacking

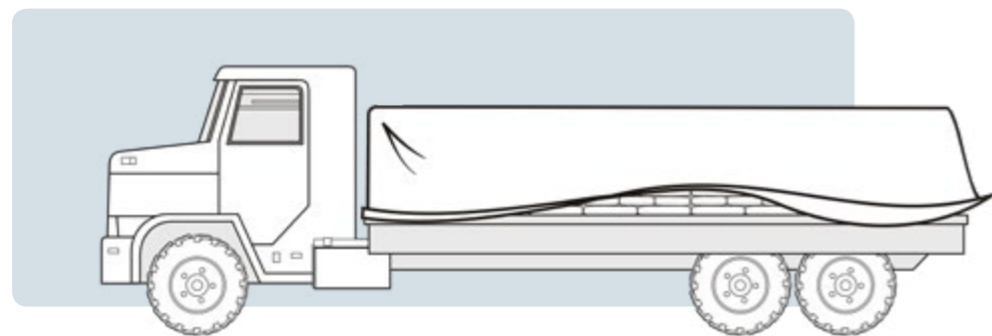

- When unloading cargo in tarps, be careful regarding the accumulation of water on top of the tarp. It should be removed by rolling it from the front to the rear of the vehicle, and never from the side, thus preventing any water that may be on the tarp from wetting the product when pulling it.
- Check the load at the time of receipt. Fill in and sign the RID (Unloading Inspection Report), which is included in the invoice. Properly filling in the RID is essential to ensure that any non-conformities are addressed. This document should be filed in, signed, stamped and delivered to the driver, along with the invoice slip.
- Packaging problems during unloading, whenever possible, should be photographed at the time of detection, while still on the vehicle. Send us the file or files of any damaged packages, plus seals, labels and Big Bag numbers so we can take the necessary steps to replace the material, as well as any corrective actions, as soon as possible. Separating the damaged packaging may be useful for future inspection.
- If you have any questions on unloading, please contact the customer service area of Braskem.

*Images for illustration purposes only.

3. Handling of palletized sacking

Handling of pallets using forklifts should be carried out according to the instructions below:

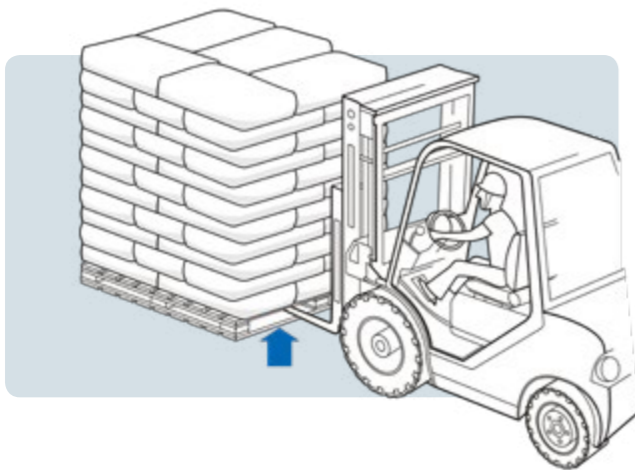

- When handling of pallets using forklifts, be careful to prevent the forks from damaging the product.
- Do not use manual pallet jacks to move the pallets with sacks. Our pallets are not suitable for movement using with this kind of equipment.

4. Storage of palletized sacking with pallet

Storage of packaging in pallets should follow the following rules:

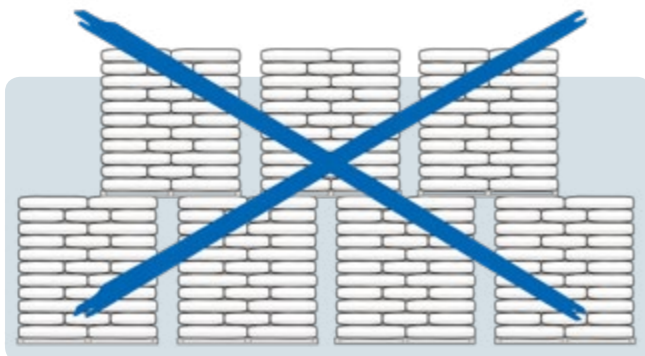

- Stacking is not recommended as it may cause fall of the material and pallets breaks. For EVA resins, the stacking also generates risk of resin agglomeration.
- Wood pallets included in the packaging should not be used in drive-type vertical structures.
- The materials should always be stored in a dry place away from light to preserve their physical and chemical properties.
- Please refer to the MSDS for information on handling and storage.

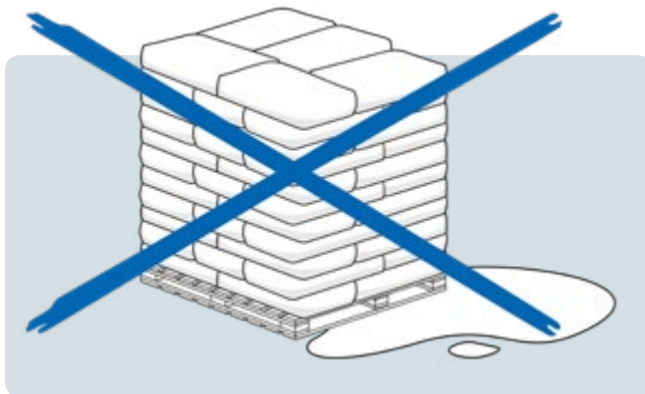

5. Handling of sacking

Disassembly of palletized sacking should be carried out according to the instructions below:

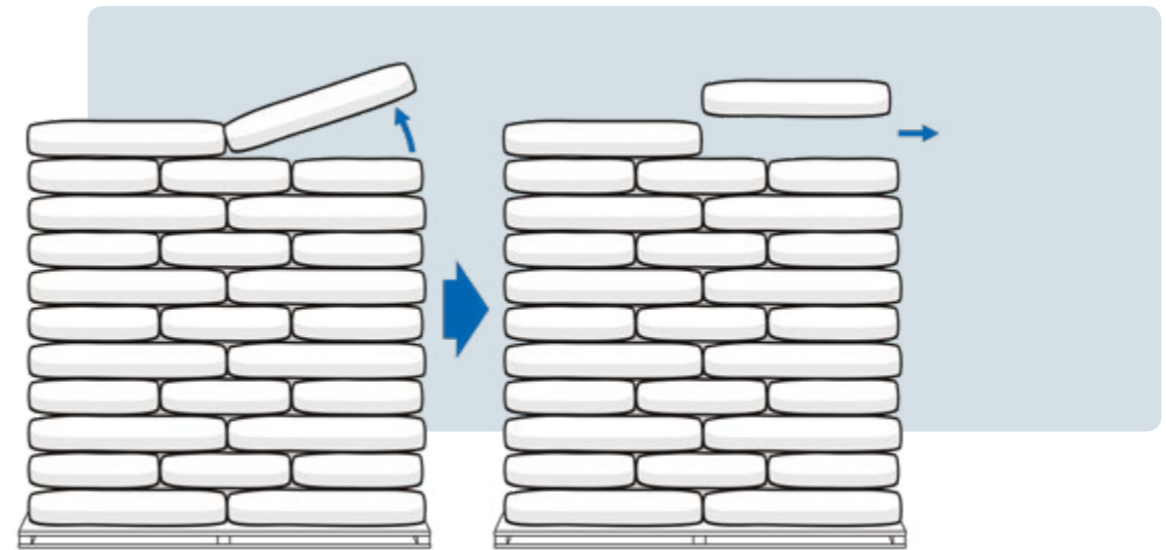

- A small amount of glue is applied between the plastic sacks stacked on the pallet. After removing the protective film, do not pull the sacks directly and horizontally. For paper sacks, do not pull the sacks by the sewing.
- The correct procedure is to first lightly suspend bag vertically and then move it to the side (horizontally), removing it from the stack.
- If you have any questions on unloading, please contact the customer service area of Braskem.

We recommend that all procedures comply with the regulations on use of the necessary PPE and CPE, as well as the applicable rules and procedures.

Bulk

Instructions for handling and movement

1. Silo truck arrival

On arrival of the silo truck, the following points should be noted:

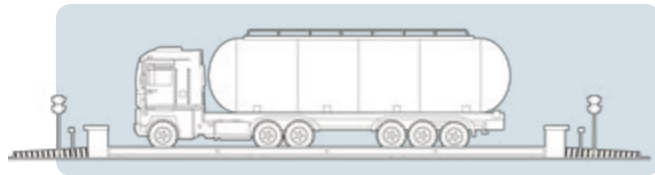

WEIGHING

- Check the weighing ticket with the volume provided in the invoice or the Braskem weighing ticket, if any. Any weight discrepancy should be noted on the RID, so that Braskem may address the issue according to the allowed tolerance.

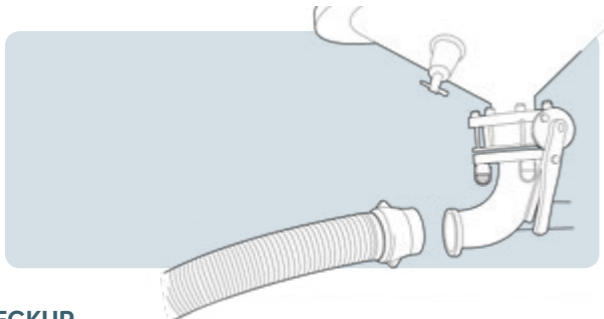

CHECKUP

- It is essential that the unloading area have a level ground in order to eliminate any risk of the truck tipping over.
- It is the client's responsibility to indicate and authorize unloading into the correct silo.
- Outlets and other connection points should not be exposed to water.



SEALS

- Check if all outputs are properly sealed, with no appearance of violation, as follows:
 1. Top inspection openings
 2. Discharge valve
- Check if the number of seals is the same as stated in the invoice.
- In case of any irregularity, do not receive the load and contact immediately the customer service area of Braskem.
- When checking the seals of the upper covers, check if they are well closed, as any opening may cause product leakage.

HOSE

- The hose for silo connection with the truck may be at the client or come with the vehicle. In both situations, it should be inspected and be in operating condition, without any apparent cracks or damage.
- The hose should be stored in a covered area and in a clean, dry place, with ends capped after use.

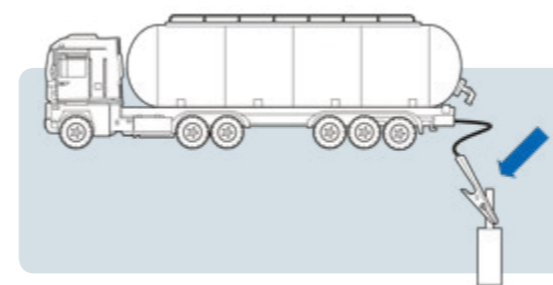

1. The truck should be grounded with the appropriate ground cable connection.

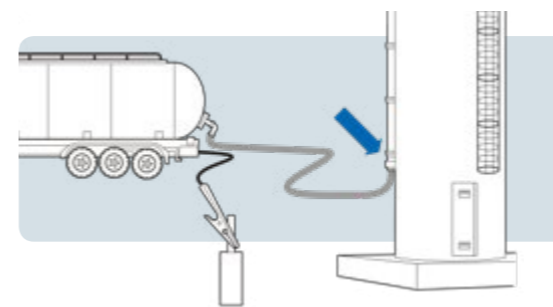

2. The unloading hose should be connected to the truck and the intended silo. Make sure that the hose connection to the silo is performed correctly in order to avoid accidents and loss of material. We recommend the use of a device that holds the two parts of the hose in order to prevent the operator from disconnecting the hose while it still has pressure, or to prevent the hose from becoming detached by itself. The use of chains and steel cables with a padlock is a good practice.

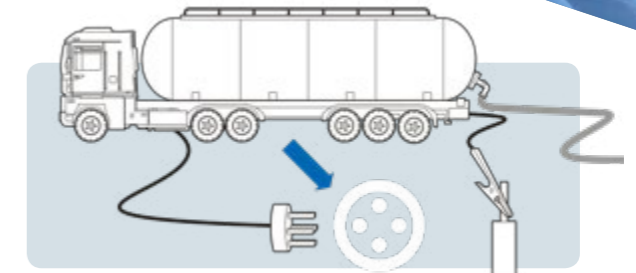

3. Indicate a compatible power outlet to connect the power cord of the truck. Connection to the outlet should be performed by a person qualified for high-voltage work (we recommend the use of LOTO procedures).

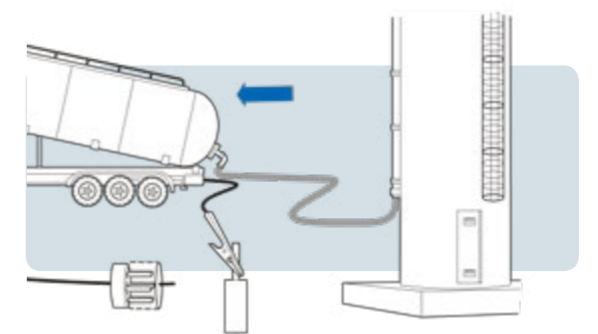

4. The truck bracket should be activated before tilting the trailer. Only after all connections are made and checked, start unloading and tilting the trailer.

We recommend that all procedures comply with the regulations on use of the necessary PPE and CPE, as well as the applicable rules and procedures.

2. Silo truck unloading

The unloading operation from the truck to the silo should be accompanied by an of the employee client to ensure that the unloading is carried out at the correct silo. The site should remain isolated for the duration of the process to prevent pedestrians from transiting in its surroundings. Perform the unloading operation according to the carrier's procedure, respecting client's security standards and following the guidelines below:

- In high-wind conditions, unloading should be stopped, as it may cause overturning of the cart.
- We recommend that the operator wear a helmet with visor for face protection in case of hose breaks and product leakage.
- If you have any questions on unloading, please contact the customer service area of Braskem.

3. Silo maintenance

- The client should keep their silos always reviewed, performing preventive maintenance to avoid possible contamination from the external environment. We suggest annual maintenance.
- In case of silos loaned by Braskem, the client should define, alongside the commercial area, the preventive maintenance plan and procedures for corrective maintenance.

Container

Instructions for handling and movement

Container with Liner (bulk product)

1. Container arrival

On receipt of the container with an inner liner, the following points should be noted:

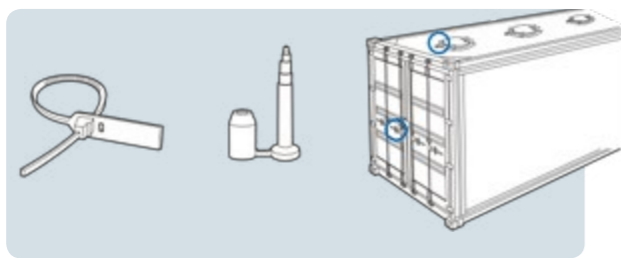

SEALS

- Check, according to the type of container, if the seals have no violation in the following items:
 - Top hatches (for deliveries in Brazil)
 - Side door
- For deliveries in Brazil, check if the numbers of seals are the same as listed in the invoice (DANFE).
- For deliveries outside Brazil, check the numbers of the seals on the Packing List.

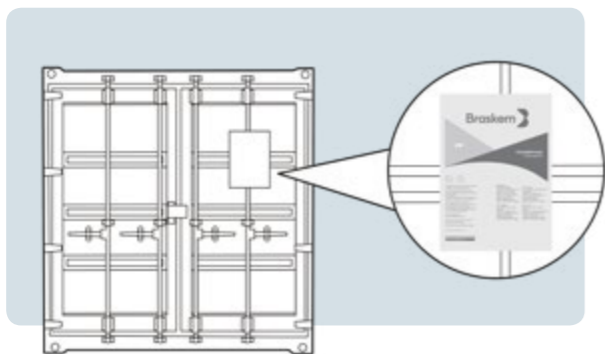

LABELING

- For deliveries in Brazil, check if the data on the label with product information, and batch number of the container coincide with the data of the invoice.
- For deliveries outside Brazil: there is no label.

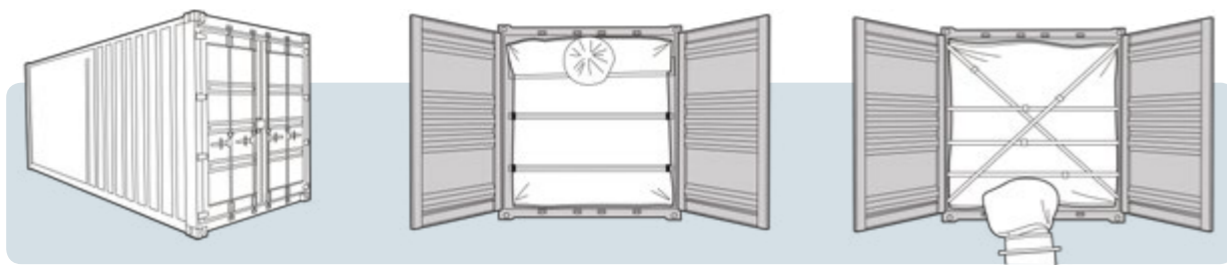

CONTAINERS

- On arrival of the container, check the cargo after opening for unloading of the product. In case of deviations, please contact the customer service area of Braskem immediately. It is advisable to attach photos to the e-mail indicating the issue.

2. Container unloading

To begin the unloading procedure, the following items should be noted:

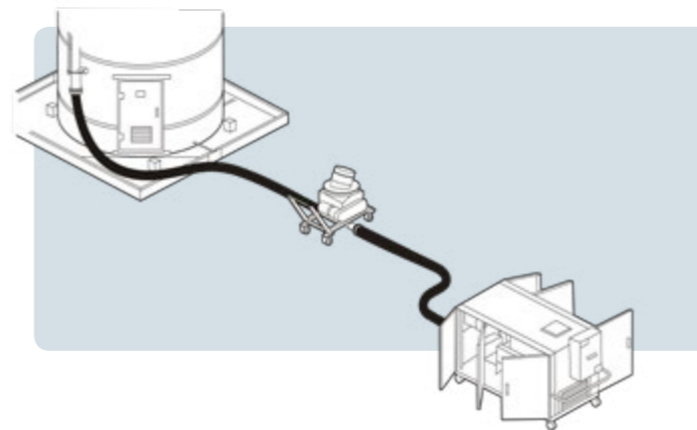

1. HOSE

- The hose should be inspected and be in operating condition, without any apparent cracks or damage. It should be stored in a covered area and in a clean, dry place, with ends capped before and after use.
- The quick coupling connections should be suitable to the fastening clips.
 - The fastening of the clamps should be adequate.

2. ROTARY VALVE

- Check if the nozzle labels and protection cover are adequate and in operating condition and if the inside is clean and dry, without product accumulated from previous unloading operations.

3. BLOWER

- Check if the cables and power outlet are in good condition, without breaks, and if the drive and emergency pushbuttons are in operating condition.

- It is essential that the unloading area have a level ground in order to eliminate any risk of the truck tipping over.
- Perform the unloading procedure according to the carrier's procedure while respecting the client's safety standards.

If you have any questions on unloading, please contact the customer service area of Braskem.

3. Silo maintenance

- The client should keep their silos always reviewed, performing preventive maintenance to avoid possible contamination from the external environment. We suggest annual maintenance.
- In case of silos loaned by Braskem, the client should define, alongside the commercial area, the preventive maintenance plan and procedures for corrective maintenance.

We recommend that all procedures comply with the regulations on use of the necessary PPE and CPE, as well as the applicable rules and procedures.

*Images for illustration purposes only.

Container

Instructions for handling and movement

Container with Big Bags or Sacking

1. Container arrival

On receipt of the container with Big Bags or sacking, the following points should be noted:

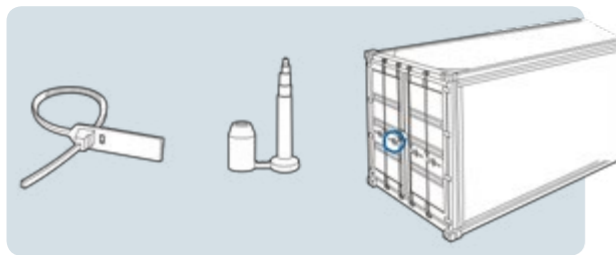

SEALS

- Check, according to the type of container, if the seals have no violation in the following items:
 - Side door
- For deliveries in Brazil, check if the numbers of seals are the same as listed in the invoice (DANFE).
- For deliveries outside Brazil, check the numbers of the seals on the Packing List.

LABELING

- Check if the data contained in the package or label containing product and batch information, if any, match the data of the invoice or Packing List.

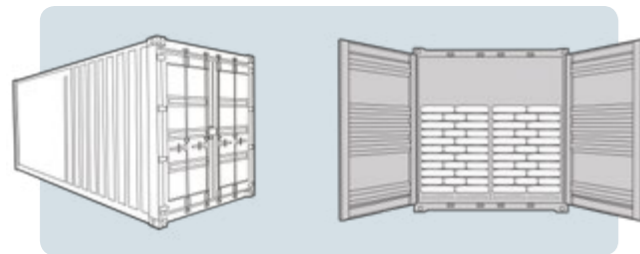

CONTAINERS

- On arrival of the container, check the cargo after opening for unloading of the product. In case of deviations, please contact the customer service area of Braskem immediately. It is advisable to attach photos to the e-mail indicating the issue.

In case of faults, it is advisable to take pictures of the product while it is still inside the container.

- For deliveries in Brazil: fill in the RID (cabotage).
- For deliveries outside Brazil: send photos and e-mail to the customer service area of Braskem.

Braskem	
RID-Relatório de Inspeção no Desembarque - comprovante de entrega	
Data: 14/02/2014	
Nome do Cliente: <input type="text"/>	Nome do Estoque: <input type="text"/>
Código do Produto: <input type="text"/>	
1. IDENTIFICAÇÃO DA REMESSA	
1.1 Descrição: <input type="text"/>	1.2 Quantidade: <input type="text"/>
1.3 Embalagem: <input type="text"/>	1.4 Data de Expediente: <input type="text"/>
2. IDENTIFICAÇÃO DA TRANSPORTADORA	
2.1 Nome: <input type="text"/>	2.2 CNPJ: <input type="text"/>
2.3 Endereço: <input type="text"/>	2.4 Telefone: <input type="text"/>
2.5 E-mail: <input type="text"/>	2.6 CEP: <input type="text"/>
3. INSPEÇÃO DE DESEMBARQUE	
3.1 Inspeção realizada em local adequado?	Sim <input type="checkbox"/> Não <input type="checkbox"/>
3.2 Desembarque realizado em local adequado?	Sim <input type="checkbox"/> Não <input type="checkbox"/>
4. DESCRIÇÃO DAS NÃO CONFORMIDADES	
4.1 Produto Faltoso:	Quantidade em kg (aproximado):
4.2 Embalagem irregular:	
4.3 Divergência de carga (quantidade, peso, qualidade, etc):	
4.4 Carga Geral - Não conformidade com base de contêiner etc:	
4.5 Observações (se o caso, se necessário):	
OBSERVAÇÕES GERAIS:	
Este documento deve ser preenchido caso haja divergência entre o que foi informado no contrato comercial e o que foi recebido. Deve ser preenchido com o número de identificação do produto, o número de lote ou de contêiner etc, se aplicável. Faltas não devem ser preenchidas para facilitar a investigação de falhas. Pode-se anexar o material fotografado para posterior análise por parte da Braskem. Para mais informações, acesse www.braskem.com	
Nome Legível do Recebedor: <input type="text"/>	
Nome Legível do Motorista: <input type="text"/>	
ASSINATURA E CARIMBO DO RECEBEDOR	DATA DE ENTREGA
ASSINATURA DO MOTORISTA	
Em caso de qualquer ocorrência que resulte em atraso desta entrega, avise imediatamente a Braskem. Este documento deve retornar à Braskem assinado e carimbado.	

2. Container unloading

Product unloading should be carried out using a forklift or pallet truck (do not use for palletized sacking). Never use ropes or other devices to move the material.

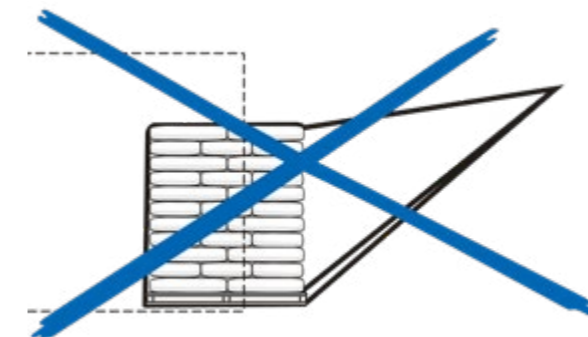
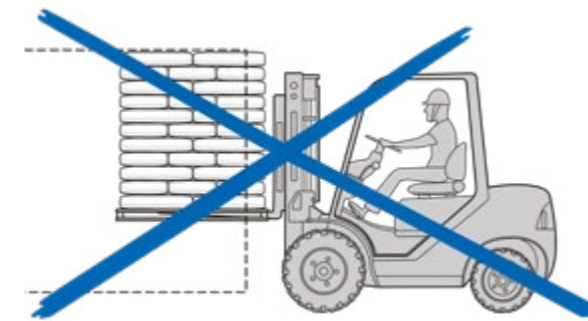
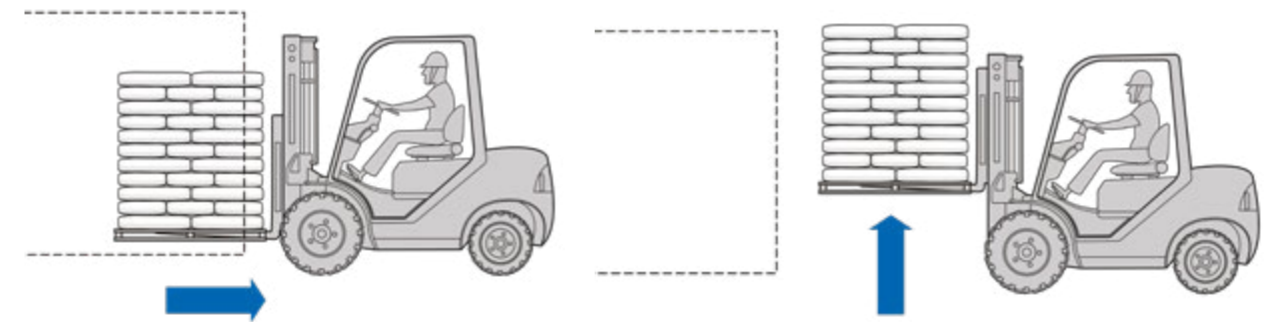

For information on handling and storage of Big Bags and palletized sacking, please refer to the corresponding instructions in this leaflet.

We recommend that all procedures comply with the regulations on use of the necessary PPE and CPE, as well as the applicable rules and procedures.

* Images for illustration purposes only.

If you have any opportunity for improvement or any suggestion to make about the products and services provide, do not hesitate to contact the customer service area of Braskem.

It is possible that this material has been updated. For the latest version, please visit the Braskem website: www.braskem.com